

15HCS

Horizontal Carton Sealer



where products meet packaging®

Looking for an affordable horizontal carton sealing solution for your new product launch or short production run? If so, the ADCO 15HCS is just what you are looking for. This compact and easy to operate continuous motion machine is capable of sealing a wide range of carton sizes at speeds up to 50 cartons per minute. Simply place a pre-filled carton into the 15HCS from either side of the load area and it will take care of the rest; quick, easy and efficient. Designed with flexibility and portability in mind, the 15HCS horizontal carton sealer is ideal for the most demanding and cost conscious production environments. Like all ADCO machines, the 15HCS is constructed in stainless steel and is available in standard or washdown configurations.

Benefits

- Stainless steel construction improves cleanability
- Positive, continuous motion lugged carton transfer maximizes control and reliability
- Fast, easy changeover improves productivity and reduces downtime
- Large carton size range protects your investment as products change
- Pressurized glue system minimizes glue consumption and reduces clean up
- Advanced guard design keeps operators safe and maximizes maintenance access
- Compact design

15HCS Horizontal Carton Sealer

Product Features

- Stainless steel construction
- Continuous motion lugged carton transfer system
- Compact frame with leveling feet and casters
- Easy access drive system
- Quick Adjust changeover
- Casters and leveling feet
- Nordson® ProBlue hot melt glue system
- Allen-Bradley® control package
- Category 3 safety system with a fully-interlocked barrier guard package
- Many options available upon request

Typical Applications

- Flow-wrapped products
- Baked goods
- Snack foods
- Frozen foods
- Consumer products
- Confectionery

Utilities

Electrical

230/460 VAC, 3-Phase with ground (PE), 60 Hz

Air Consumption

2-3 CFM @ 95 PSI

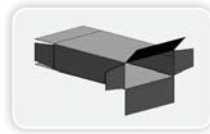

PLAN VIEW

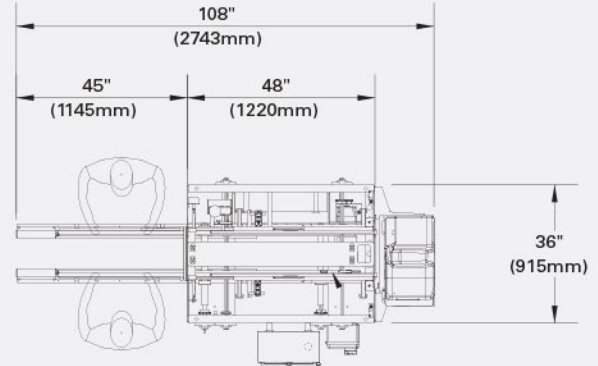

SIDE ELEVATION

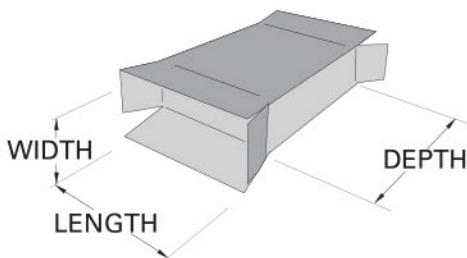
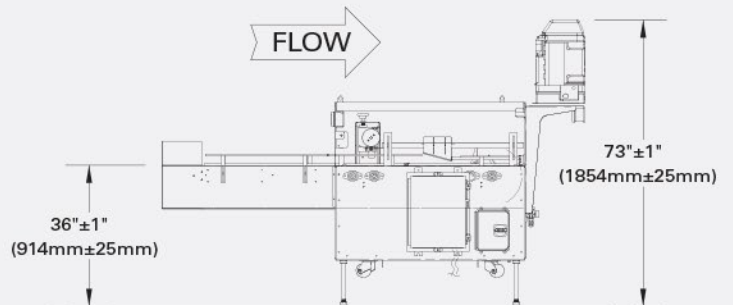

CARTON SIZE RANGE

Dimensions	(in)		(mm)	
	Min	Max	Min	Max
Length of Opening	2	12	12	305
Width of Opening	0.75	4.5	20	115
Carton Depth	3.5	12	90	305

Not all minimums and maximums apply.
Special modifications are available to extend the size range.



For more information on this product, scan the QR code with your mobile device.



DARTRONICS, INC.

PACKAGING AUTOMATION SPECIALISTS



150 WILLIAM ST. PERTH AMBOY, NJ 08861 / TOLL FREE: 800-298-8936 / PHONE: 732-324-0800 / FAX: 732-324-4488

WWW.DARTRONICS.COM

YOUTUBE / DARTRONICS

THE SINGLE SOURCE FOR YOUR

END-OF-LINE

PACKAGING, MARKING AND CODING NEEDS