

NERLITE® BACKLIGHT

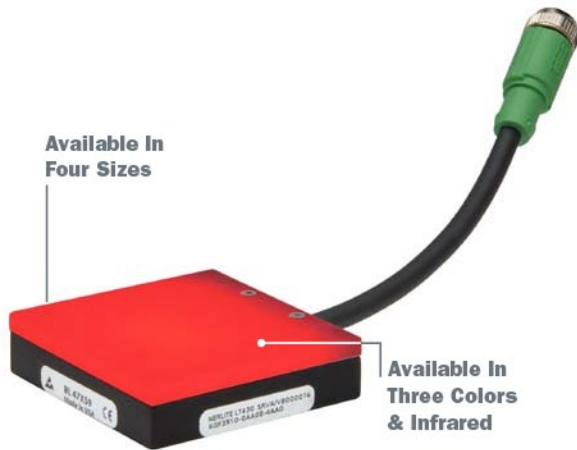

Edge To Edge Back Lighting

Microscan's wide range of NERLITE products can illuminate any part or mark for successful machine vision and auto ID applications.

The Edge To Edge series of backlight illuminators provide sharp contrast to outline a part's shape, find edges and view openings such as drilled holes. Edge To Edge technology allows combining multiple lights to address large field of view applications. High intensity and uniformity are packed into a low-profile industrial package for optimal thermal management.

Backlight: At a Glance

- Multiple lights may be combined to create larger illuminated areas
- Variety of colors and wavelengths for both continuous and strobed power sources
- High level of uniformity for repeatable results
- M12 connectors for easy connections to power supplies, drivers or advanced controllers
- Low profile, compact shape for flexible integration

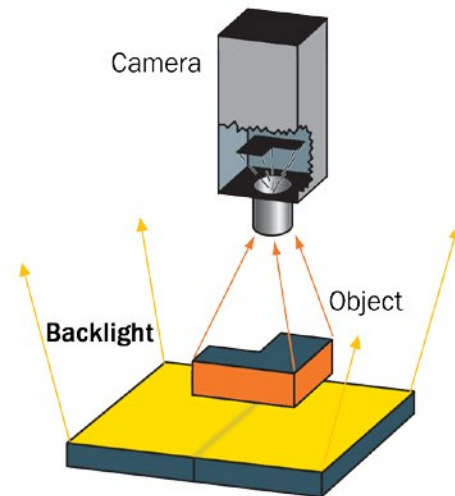

Illumination Example:

Object



Resulting Image

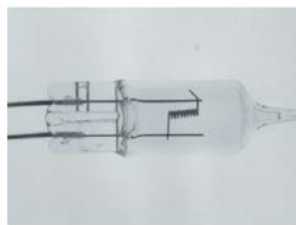

Light bulb: Resulting image clearly shows silhouette of filament inside the bulb.

For more information on this product, visit www.microscan.com.

Application Examples

- Locate or measure outside dimensions
- View openings (e.g., drilled holes)
- Diminish clear glass or plastic housings
- Measure thickness of materials
- Locate mounting holes
- Measure translucency
- Diffuse incident (front) lighting

MICROSCAN®

NERLITE® EDGE TO EDGE BACKLIGHT SPECIFICATIONS AND OPTIONS

BACKLIGHT 47x59

DESCRIPTION	nm/K	CONT. CURRENT	STROBE CURRENT	mcd/cm ²	mw/cm ²
BL, 47x59, Red Continuous	640 nm	93 mA		77	
BL, 47x59, Red Strobe	640 nm		2.67 A	1100	
BL, 47x59, White Continuous	6500 K	201 mA		880	
BL, 47x59, White Strobe	6500 K		3.34 A	11670	
BL, 47x59, Blue Continuous	470 nm	170 mA		177	
BL, 47x59, Blue Strobe	470 nm		3.0 A	2510	
BL, 47x59, Infrared Continuous	880 nm	140 mA			1.6
BL, 47x59, Infrared Strobe	880 nm		4.0 A		23

Active Area: 1.9" x 2.3" (47 mm x 59 mm) **Weight:** 3 oz. (80 g)
Dimensions: H 2.28" (58 mm) x W 2.3" (59 mm) x D 0.6" (15.2 mm)

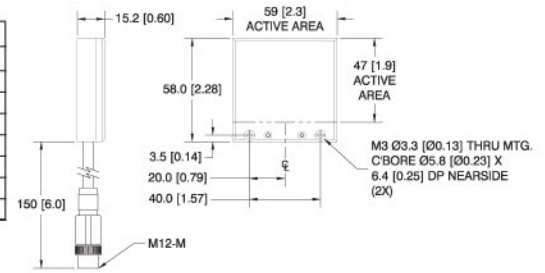

BACKLIGHT 71x88

DESCRIPTION	nm/K	CONT. CURRENT	STROBE CURRENT	mcd/cm ²	mw/cm ²
BL, 71x88, Red Continuous	640 nm	170 mA		77	
BL, 71x88, Red Strobe	640 nm		5.01 A	1135	
BL, 71x88, White Continuous	6500 K	330 mA		810	
BL, 71x88, White Strobe	6500 K		9.0 A	11050	
BL, 71x88, Blue Continuous	470 nm	310 mA		175	
BL, 71x88, Blue Strobe	470 nm		9.0 A	2575	
BL, 71x88, Infrared Continuous	880 nm	220 mA			1.5
BL, 71x88, Infrared Strobe	880 nm		7.5 A		26

Active Area: 2.8" x 3.5" (71 mm x 88 mm) **Weight:** 5 oz. (140 g)
Dimensions: H 3.21" (81.6 mm) x W 3.5" (88 mm) x D 0.6" (15.2 mm)

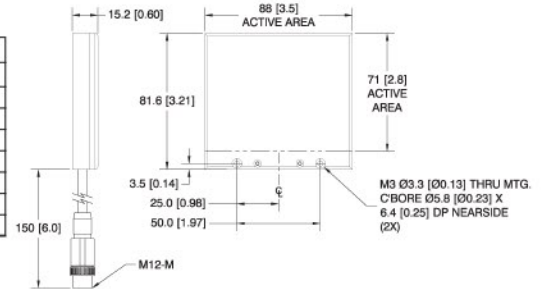

BACKLIGHT 100x100

DESCRIPTION	nm/K	CONT. CURRENT	STROBE CURRENT	mcd/cm ²	mw/cm ²
BL, 100x100, Red Continuous	640 nm	155 mA		95	
BL, 100x100, Red Strobe	640 nm		4.99 A	700	
BL, 100x100, White Continuous	6500 K	350 mA		625	
BL, 100x100, White Strobe	6500 K		9.98 A	7100	
BL, 100x100, Blue Continuous	470 nm	320 mA		125	
BL, 100x100, Blue Strobe	470 nm		9.98 A	1570	
BL, 100x100, Infrared Continuous	880 nm	250 mA			1
BL, 100x100, Infrared Strobe	880 nm		7.99 A		16

Active Area: 3.9" x 3.9" (100 mm x 100 mm) **Weight:** 7 oz. (200 g)
Dimensions: H 4.36" (110.9 mm) x W 3.9" (100 mm) x D 0.66" (16.8 mm)

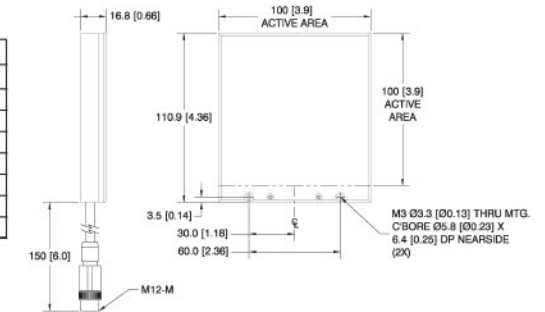

BACKLIGHT 50x200

DESCRIPTION	nm/K	CONT. CURRENT	STROBE CURRENT	mcd/cm ²	mw/cm ²
BL, 50x200, Red Continuous	640 nm	155 mA		95	
BL, 50x200, Red Strobe	640 nm		4.99 A	700	
BL, 50x200, White Continuous	6500 K	350 mA		625	
BL, 50x200, White Strobe	6500 K		9.98 A	7100	
BL, 50x200, Blue Continuous	470 nm	320 mA		125	
BL, 50x200, Blue Strobe	470 nm		9.98 A	1570	
BL, 50x200, Infrared Continuous	880 nm	250 mA			1
BL, 50x200, Infrared Strobe	880 nm		7.99 A		16

Active Area: 2.0" x 7.9" (50 mm x 200 mm) **Weight:** 8 oz. (230 g)
Dimensions: H 2.4" (60.9 mm) x W 7.9" (200 mm) x D 0.66" (16.8 mm)

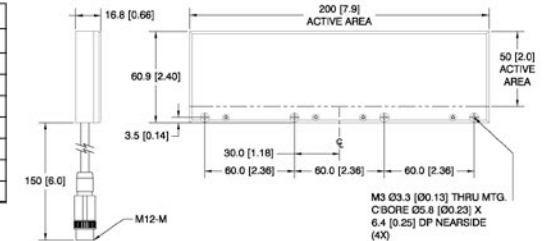

ENVIRONMENTAL

Operating Temperature: 0° to 40° C (32° to 104° F)
Storage Temperature: 0° to 50° C (32° to 122° F)
Humidity: up to 95% (non-condensing)

LIGHTING PARAMETERS

Active Area Defined: Area of light output from the illuminator

LIGHT SOURCE

Type: High output LEDs
Light Output: Millicandelas per square centimeter (mcd/cm²)
Radiant Output: Milliwatts per square centimeter (mw/cm²)
Expected Life: 50,000 hours
Eye Safety: EN 60825-1: Class 1 (Red, White, Infrared LEDs); Class 2 (Blue LEDs)

CONNECTOR

Type: 6 in. (150 mm) cable terminated with 4-pin M12 male connector

ELECTRICAL

Power (Continuous Models): 24 VDC +/- 1%
Power (Strobe Models): 1 ms max. pulse width, 6% max duty cycle, use of NERLITE NL-200 Series Lighting Controller is required.



DARTRONICS, INC.

PACKAGING AUTOMATION SPECIALISTS



150 WILLIAM ST. PERTH AMBOY, NJ 08861 / TOLL FREE: 800-298-8936 / PHONE: 732-324-0800 / FAX: 732-324-4488

WWW.DARTRONICS.COM

YOUTUBE / DARTRONICS

THE SINGLE SOURCE FOR YOUR

END-OF-LINE

PACKAGING, MARKING AND CODING NEEDS