

MS-2D

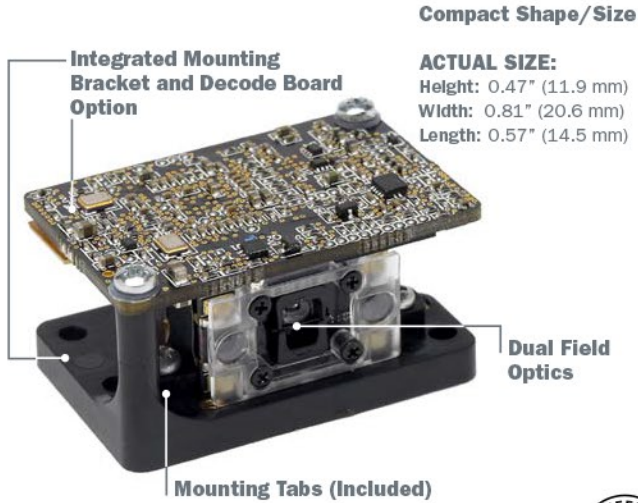

2D Imaging Engine

The MS-2D engine is an ultra-compact barcode imaging system that can be easily integrated into any device. Featuring advanced technologies for decoding, the MS-2D engine includes a dual optical field for reliable reading of both large 1D barcodes and high density 2D symbols.

Designed specifically for embedded applications, the MS-2D engine provides the best performance available for reading 1D/2D symbols and direct part marks at very close range.

MS-2D Engine: At a Glance

- Ultra-fast Microprocessor
- Dual Field Optics for Both Wide and High Density Fields
- X-Mode Technology for High Performance Decoding
- USB 2.0, RS-232 Interface Options
- Low 5V Power Draw



ESP® Easy Setup Program: Single-point software provides quick and easy setup and configuration of all Microscan readers.

For more information on this product, visit www.microscan.com.

Compact & Lightweight

The MS-2D decode board has a footprint of 1.54" W by 0.98" D by 0.30" H (39.0 mm W by 24.9 mm D by 7.6 mm H) and weighs only 0.10 oz. (2.8 g).

Reading Capabilities

The MS-2D engine with X-Mode decoding algorithms can easily read the most damaged or difficult codes and symbols, including direct part marks.

Easy Setup

ESP software provides easy configuration of the MS-2D engine, including selectable trigger and symbology setting.

Multiple Configurations

A variety of mounting features are available including tabs, blind through holes, and mounting brackets. Configuration options include integrated decode board and mounting bracket, or low profile tab mount with remote decode board.

Application Examples

- Clinical instruments
- Medical devices
- Electronics assembly
- Kiosks and bank ATMs

MS-2D Engine: Available Codes

Linear	All Standard 	Postal Codes 		
Stacked	MicroPDF 	PDF417 	GS1 Databar 	
2D	Data Matrix 	QR 	Micro QR 	Aztec 

MS-2D ENGINE SPECIFICATIONS AND OPTIONS

ENGINE WITH TABS

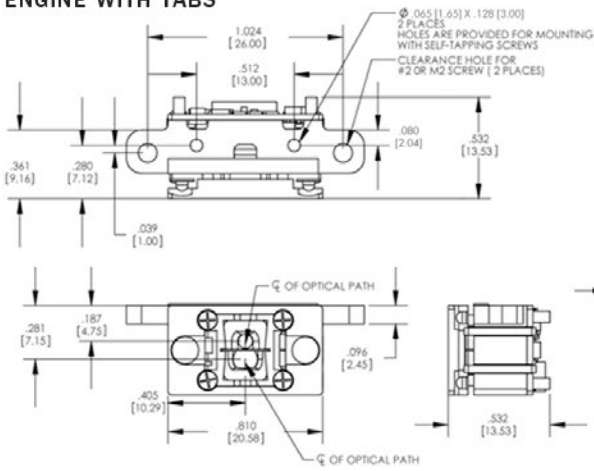

DECODE BOARD

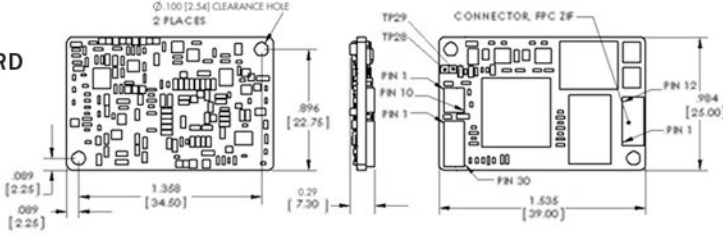

Note: Inches [millimeters]. Nominal dimensions shown. Typical tolerances apply.

MECHANICAL (ENGINE)

Height: 0.47" (11.9 mm)
Width: 0.81" (20.6 mm)
Length: 0.57" (14.5 mm)
Weight (Without Mounting Tabs): 0.09 oz. (2.6 g)

MECHANICAL (DECODE BOARD)

Height: 1.54" (39.0 mm)
Width: 0.98" (24.9 mm)
Length: 0.30" (7.6 mm)
Weight: 0.10 oz. (2.8 g)

MECHANICAL (INTEGRATED UNIT)

Height: 1.54" (39.0 mm)
Width: 0.98" (24.9 mm)
Length: 0.86" (21.8 mm)
Weight: 0.91 oz. (25.7 g)

LIGHT SOURCE

Type: High output red LED illumination
Target Beam: Blue LED

LIGHT COLLECTION OPTIONS

Sensor: CMOS 1.2 Megapixel
Optical Resolution: 960 x 640 pixels, both high density and wide

SCANNING PERFORMANCE

Pitch: $\pm 60^\circ$ (from front to back)
Skew: $\pm 60^\circ$ from plane parallel to symbol (side-to-side)
Tilt: $\pm 180^\circ$

Print Contrast Resolution:

25% (1D symbologies), 35% (2D symbologies) absolute dark/light reflectance differential, measured at 650 nm

COMMUNICATION

Interface: USB 2.0, RS-232 TTL
Memory: 128MB Flash ROM, 32MB RAM

SYMBOLOGIES

2D Symbologies: Data Matrix (ECC 0-200), QR Code, Micro QR Code, Aztec Code

Stacked Symbologies: PDF417, Micro PDF417, GS1 Databar (Composite & Stacked)

Linear Barcodes: Code 39, Code 128, BC 412, I2 of 5, UPC/EAN, Codabar, Code 93, Pharmacode, PLANET, PostNet, Japanese Post, Australian Post, Royal Mail, Intelligent Mail, KIX

ENVIRONMENTAL CHARACTERISTICS

Operating Temperature: -20° to 55° C (-4° to 131° F)

Storage Temperature: -30° to 65° C (-22° to 150° F)

Relative Humidity:

5% to 95% (non-condensing)

Ambient Light Immunity: Sunlight: Up to 9,000 ft-candles/96,800 lux

Shock: Withstands multiple drops of 6' (1.8 m) to concrete in an enclosed housing

INDICATORS

Symbol Locator: Blue LED targeting beam
Beeper: Good read

ELECTRICAL

Power: 5 VDC

Typical: 303 mA **Idle:** 57 mA **Sleep:** 1.6 mA

CE STANDARDS

Emissions: EN 55022:2006 Class B Limits; ICES-003

LED Safety: EN 60825-1: 1994+A1+A2 Class 1

INTEGRATED UNIT

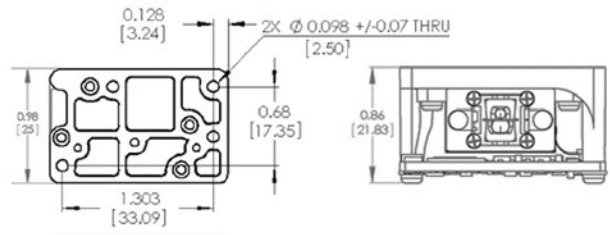

READ RANGE GRAPH

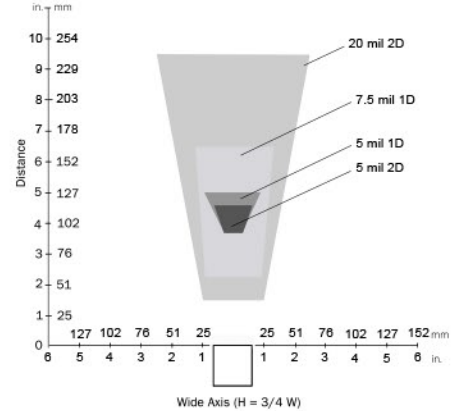

READ RANGE TABLE

Narrow-Bar	Read Range
STANDARD DENSITY	
1D	
.0050" (.127 mm)	3.7 to 5.0" (94 to 127 mm)
.0075" (.191 mm)	2.2 to 6.5" (56 to 165 mm)
.010" (.254 mm)	1.5 to 8.0" (38 to 203 mm)
.020" (.508 mm)	2.3 to 15.5" (58 to 394 mm)
2D	
.0050" (.127 mm)	3.7 to 4.6" (94 to 117 mm)
.0075" (.191 mm)	1.5 to 6.0" (38 to 152 mm)
.010" (.254 mm)	1.6 to 7.7" (41 to 196 mm)
.020" (.508 mm)	1.6 to 9.4" (41 to 239 mm)

Note: Specifications are subject to change. Working ranges are a combination of both the wide and high density fields.

SAFETY CERTIFICATIONS DESIGNED FOR FCC, CE

ROHS/WEEE COMPLIANT

ISO CERTIFICATION

Certified ISO 9001:2008 Quality Management System

©2015 Microscan Systems, Inc. SP074G-EN-1013

Read Range and other performance data is determined using high quality Grade A symbols per ISO/IEC 15415 and ISO/IEC 15416 in a 25° C environment. For application-specific Read Range results, testing should be performed with symbols used in the actual application. Microscan Applications Engineering is available to assist with evaluations. Results may vary depending on symbol quality. **Warranty**—For current warranty information on this product, please visit www.microscan.com/warranty.



DARTRONICS, INC.

PACKAGING AUTOMATION SPECIALISTS



150 WILLIAM ST. PERTH AMBOY, NJ 08861 / TOLL FREE: 800-298-8936 / PHONE: 732-324-0800 / FAX: 732-324-4488

WWW.DARTRONICS.COM

YOUTUBE / DARTRONICS

THE SINGLE SOURCE FOR YOUR

END-OF-LINE

PACKAGING, MARKING AND CODING NEEDS