

Compact 4

Vertical End Load Cartoner



where products meet packaging®

Featuring the patented “Stella” 8-pocket quick size adjust starwheel, the ADCO Compact 4 was designed to form, load and seal small to medium size vertical end load cartons. The patented design can be configured with fully automatic product and leaflet loading options as well. With its space-saving footprint and flexible design, the Compact 4 is ideal for pharmaceutical and cosmetic packagers. This simple to operate and ergonomically designed machine includes two standard hand load stations coupled with lights curtains and product sensors for safe, automatic machine cycling speeds up to 40 cartons per minute. Like all ADCO machines, the Compact 4 is constructed in stainless steel and is available in standard or washdown configurations.

Benefits

- Stainless steel construction improves cleanability and eliminates corrosion
- Patented “Stella” 8-pocket quick adjust starwheel maximizes productivity and uptime
- Load area light curtains and product sensors ensure safe and efficient machine cycling
- Ergonomically designed product load area minimizes fatigue and maximizes productivity
- Flexible design minimizes changeover time and protect investment as products change

Compact 4 Vertical End Load Cartoner

Product Features

- Stainless steel construction
- Compact design with integrated stand and locking casters
- Ergonomically designed product load areas
- Quick adjust levers and scales on all adjustments
- Configurable with fully automatic product and leaflet loading options
- Allen-Bradley® PLC control package
- Capable of erecting and sealing tablock tuck style or glued cartons
- Nordson® ProBlue 4 hot melt glue system (when glue is specified)
- Advance guarding with light curtains and product sensors
- Many options available upon request

Typical Applications

- Pharmaceutical products
- Cosmetics
- Household products
- Novelties
- Candy and confectionery

Utilities

Electrical

230/460 VAC, 3-Phase with ground (PE), 60 Hz

Air Consumption

2-3 CFM @ 65-70 PSI



PLAN VIEW

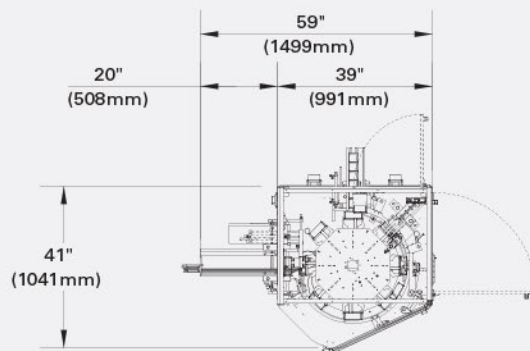

SIDE ELEVATION

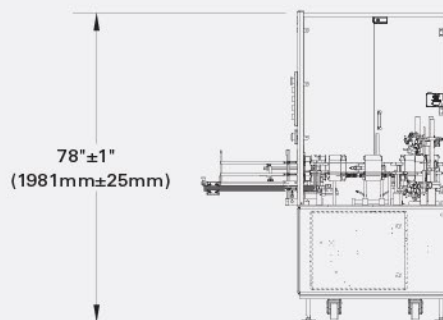

Optional Tall Machine and Optional Feet shown in side elevation above.

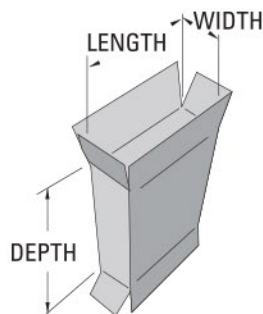

CARTON SIZE RANGE

Dimensions	(in)		(mm)	
	Min	Max	Min	Max
Length of Opening	1	4.72	25	120
Width of Opening	0.71	4.54	18	90
Carton Depth	2.36	7.09	60	180

Not all minimums and maximums apply.
Special modifications are available to extend the size range.



For more information on this product, scan the QR code with your mobile device.



DARTRONICS, INC.

PACKAGING AUTOMATION SPECIALISTS



150 WILLIAM ST. PERTH AMBOY, NJ 08861 / TOLL FREE: 800-298-8936 / PHONE: 732-324-0800 / FAX: 732-324-4488

WWW.DARTRONICS.COM

YOUTUBE / DARTRONICS

THE SINGLE SOURCE FOR YOUR

END-OF-LINE

PACKAGING, MARKING AND CODING NEEDS