

CVC300 Wrap Labeler

- Lower Operating Costs

- Increase Operating Flexibility

- Unparalleled Service

- Quality that your Customers Demand



The CVC300 Wrap Labeler is built to automatically apply pressure sensitive labels onto round containers. It is an ideal machine for contract packagers and manufacturers serving the nutraceutical, food, cosmetic, personal care, and household product markets.

*All CVC labelers include our patented **Self Set™** software which utilizes a high frequency encoder for extremely easy setup and wrinkle free labeling at the touch of a button.*

Labelers

Solid Dose Bottling Lines
Blister Packaging
Cartoning



DARTRONICS, INC.

PACKAGING AUTOMATION SPECIALISTS



150 WILLIAM ST. PERTH AMBOY, NJ 08861 / TOLL FREE: 800-298-8936 / PHONE: 732-324-0800 / FAX: 732-324-4488

WWW.DARTRONICS.COM

YOUTUBE / DARTRONICS

THE SINGLE SOURCE FOR YOUR

END-OF-LINE

PACKAGING, MARKING AND CODING NEEDS

CVC300 Technical Specifications

Standard Features:

- Self Set Auto Adjusting Control System
- Stainless Steel Frame on lockable casters
- Stainless Steel flat bed conveyor with 4" wide table top chain (Raised Sanitary Bed)
- 25-Key Hand Held Terminal with LCD Display
- Label head with up to $\pm 1/32$ " accuracy and Integrated Wrap Station
- Label Sensor for Paper or Opaque Labels
- Product Sensor with Opaque and Clear Bottle Mode
- Variable Speed Separator Wheel
- Capacity up to 170 bottles per minute (BPM)
- ISO 9001:2000 Certified

Container Specifications:

- Bottle Height: 1" up to 12" (25mm - 305mm)
- Bottle Diameter: 1" to 7" (25mm - 178mm)
(dependent on conveyor width)

Label Specifications:

- Label Width/Height: 3/8" to 9" (10mm - 229mm)
(dependent on labeling head type)
- Label Length: 5/8" to 12" (16mm - 305mm)
- Label Roll: max 14" (356mm) outside diameter with 3" core
- Label Head Dispense Speed: Maximum 38 Meters/Min.

Machine Specifications:

- Conveyor Width: Standard 4", available in 4-1/2" and 6"
- Conveyor Length: Standard 79", available in 94" (sanitary)
- Conveyor Bed Height: Standard 36" (± 2 ")
- Machine Weight: 180kg

Air/Electrical Requirements:

- Power: 110V, Single Phase, 6 AMP
(208V Available on Request)
- Air: 4 cfm (only required when using Lot/Date Printer)

Available Options:

Printing:

- Hot Stamp (Lot/Date Coding)
Print Area: 2-3/4"(70mm)W x 2-1/2"(65mm)H
Type Sizes: 1.5mm, 2.0mm, or 2.5mm
Chase Size: 6 Lines of 13-22 Characters each
Low Ribbon Sensor
- Integrated Thermal Encoder (Lot/Date, Bar Code and Graphics)

Assemblies:

- Adjustable Tilt for Tapered Bottles
- Feed Screw
- Loading and Collecting Turn Tables
- Infeed and Outfeed Conveyor Extensions
- Custom Wrap Belts
- Clear Label Sensor
- Low Label Sensor (Factory Installed Only)
- Raised Sanitary Bed Conveyor

Machine Layouts:

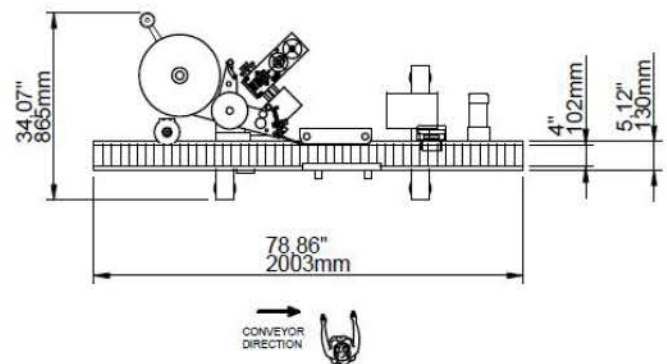

Top View

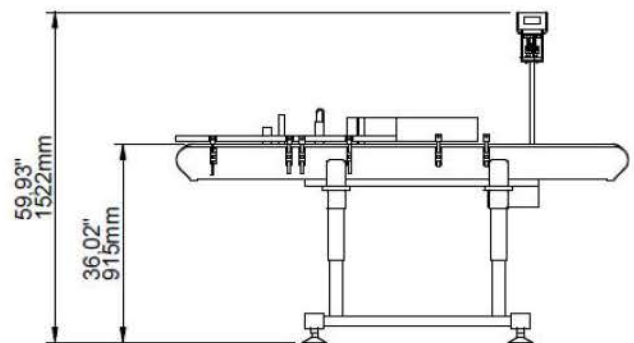

Front View

Dimensions shown are for standard machine. Conveyor can be extended or length may vary based on options selected. This labeler can run independently or be integrated into an automated packaging line.



DARTRONICS, INC.
PACKAGING AUTOMATION SPECIALISTS

THE SINGLE SOURCE FOR YOUR

END-OF-LINE

PACKAGING, MARKING AND CODING NEEDS

WWW.DARTRONICS.COM