

CVC430 Front & Back Labeler with Wrap Station

- Lower Operating Costs

- Increase Operating Flexibility

- Unparalleled Service

- Quality that your Customers Demand



The CVC430 Front & Back Labeler with Wrap Station is a dual purpose machine built to automatically apply *pressure sensitive* labels onto the front and/or back of containers and has a separate station for wrapping labels onto round containers. It can also be ordered with an optional assembly for applying a label to 3, 4, or 5 panels of a square or rectangular container. 3 Applications in 1 Machine! The 430 can be ordered with one or two labeling heads and is an ideal machine for contract packagers and manufacturers serving the food, nutraceutical, pharmaceutical, gas, oil, and personal care markets.

All CVC labelers include our patented Self Set™ software which utilizes a high frequency encoder for extremely easy setup and wrinkle free labeling at the touch of a button.

Labelers

Solid Dose Bottling Lines
Blister Packaging
Cartoning



DARTRONICS, INC.

PACKAGING AUTOMATION SPECIALISTS



150 WILLIAM ST. PERTH AMBOY, NJ 08861 / TOLL FREE: 800-298-8936 / PHONE: 732-324-0800 / FAX: 732-324-4488

WWW.DARTRONICS.COM

YOUTUBE / DARTRONICS

THE SINGLE SOURCE FOR YOUR

END-OF-LINE

PACKAGING, MARKING AND CODING NEEDS

CVC430 Technical Specifications

Standard Features:

- Self Set Auto Adjusting Control System
- Stainless Steel Frame on lockable casters
- Stainless Steel flat bed conveyor with 3-1/4" wide table top chain
- 25-Key Hand Held Terminal with LCD Display
- Label head with up to $\pm 1/32$ " accuracy and Integrated Wrap Station
- Label Sensor for Paper or Opaque Labels
- 12" Long Wrap Station
- Product Sensor with Opaque and Clear Bottle Mode
- Variable Speed Separator Wheel
- Capacity: up to 175 bottles per minute (BPM)
- ISO 9001:2000 Certified

Container Specifications:

- Bottle Height: 2" to 16" (51mm - 406mm)
- Bottle Width: 1/2" to 6-1/4" (13mm - 159mm)
(dependent on conveyor width)
- Bottle Length: 1/2" to 12" (13mm - 305mm)

Label Specifications:

- Label Width/Height: 5/8" to 9" (16mm - 229mm) (dependent on labeling head type)
- Label Length: 5/8" to 12" (16mm - 305mm)
- Label Roll: max 14" (356mm) outside diameter with 3" core
- Label Head Dispense Speed: Maximum 23 Meters/Min.

Machine Specifications:

- Conveyor Width: Standard 3-1/2", available in 6"
- Conveyor Length: Standard 94-1/2"
- Conveyor Bed Height: Standard 36" (± 2 ")
- Machine Weight: 324kg

Air/Electrical Requirements:

- Power: 110V, Single Phase, 5 AMP
(220V Available on Request)
- Air: 4 cfm (only required when using Lot/Date Printer)

Available Options:

Printing:

- Hot Stamp (Lot/Date Coding)
 - Print Area: 2-3/4"(70mm)W x 2-1/2"(65mm)H
 - Type Sizes: 1.5mm, 2.0mm, or 2.5mm
 - Chase Size: 6 Lines of 13-22 Characters each
- Integrated Thermal Encoder (Lot/Date, Bar Code and Graphics)

Assemblies:

- Adjustable Tilt for Tapered Bottles
- Feed Screw
- Loading and Collecting Turn Tables
- Infeed and Outfeed Conveyor Extensions
- Chain alignment
- Clear Label Sensor
- Low Label (Factory installed Only)
- Push and Press
- Raised Sanitary Bed conveyor (Factory installed only)

Machine Layouts:

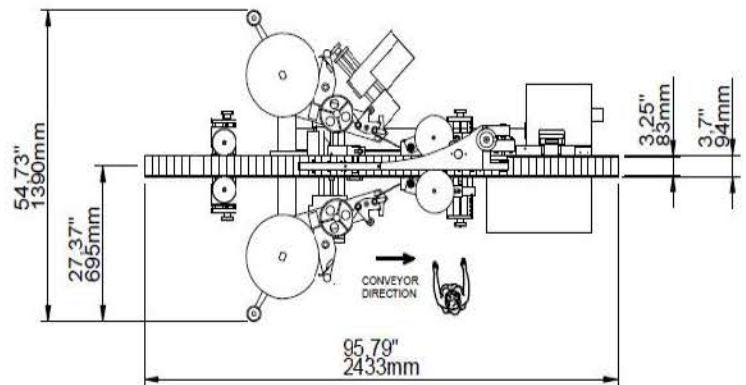

Top View

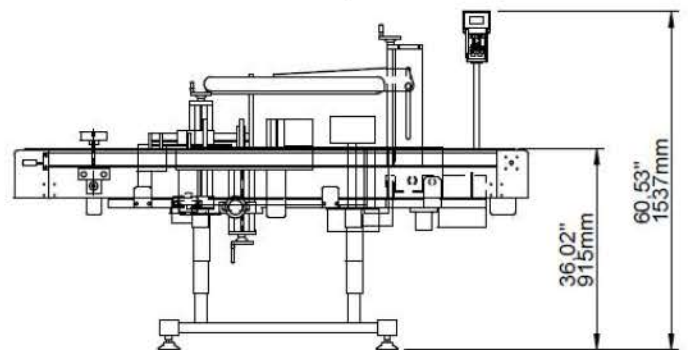

Front View

Dimensions shown are for standard machine. Conveyor can be extended or length may vary based on options selected. This labeler can run independently or be integrated into an automated packaging line.



THE SINGLE SOURCE FOR YOUR

END-OF-LINE

PACKAGING, MARKING AND CODING NEEDS

WWW.DARTRONICS.COM