

UID LDP COMPLIANCE VERIFIER

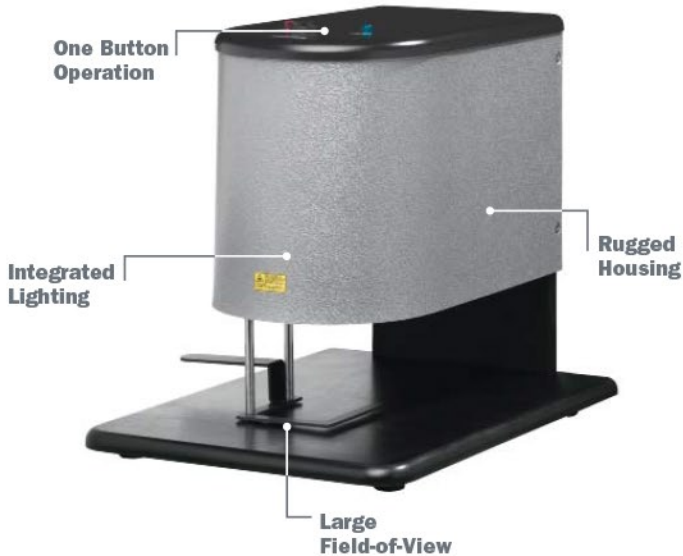

LDP Verifier

The LDP Verifier (for Labels and Data Plates) is a UID Compliance Verifier that evaluates and verifies symbols according to specifications in MIL-STD-130 and DFAR 252.211-7003. The LDP Verifier has been specially developed for checking and verifying UID Data Matrix markings on labels and data plates.

UID Compliance Verification products allow U.S. DoD (Dept. of Defense) suppliers and subcontractors to easily and consistently comply with a wide range of UID regulations.

LDP Verifier: At a Glance

- *Verification Standards:*
 - ISO/IEC 16022
 - ISO/IEC 15415
 - AS9132
 - AIM DPM Guidelines
 - MIL-STD-130
- Ethernet Connectivity
- Easy One Button Calibration and Operation
- Secure Mode For Operation Within Secure Facilities

For more information on this product, visit www.microscan.com.

LDP Verifier: Available Codes

2D Symbols

Data Matrix



Labels and Data Plates

The LDP Verifier is designed for verification of labels and data plates with thickness up to 0.125 inch (3.17 mm).

Integrated Design

The LDP Verifier is a standalone unit, connected to a host PC, that contains appropriately fixed lens and lighting systems required for testing UID data syntax strings and evaluating symbol quality.

Reports

The LDP Verifier includes reporting features with quality assurance and repeatable/auditable results. Reports are detailed, and verification results are archived for backup and compliance audits.

UID Compliance

Since implementation of the UID initiative, most goods destined for the U.S. DoD must be permanently marked with a UID code. UID Compliance Verifiers enable the DoD and their suppliers and subcontractors to meet the requirements in UID standards such as MIL-STD-130 and DFAR 252.211-7003.

Application Examples

- U.S. DoD suppliers of:
- Aerospace parts
 - Automotive parts
 - Electronics
 - Any UID Data Matrix labels and data plates

UID LDP COMPLIANCE VERIFIER SPECIFICATIONS AND OPTIONS

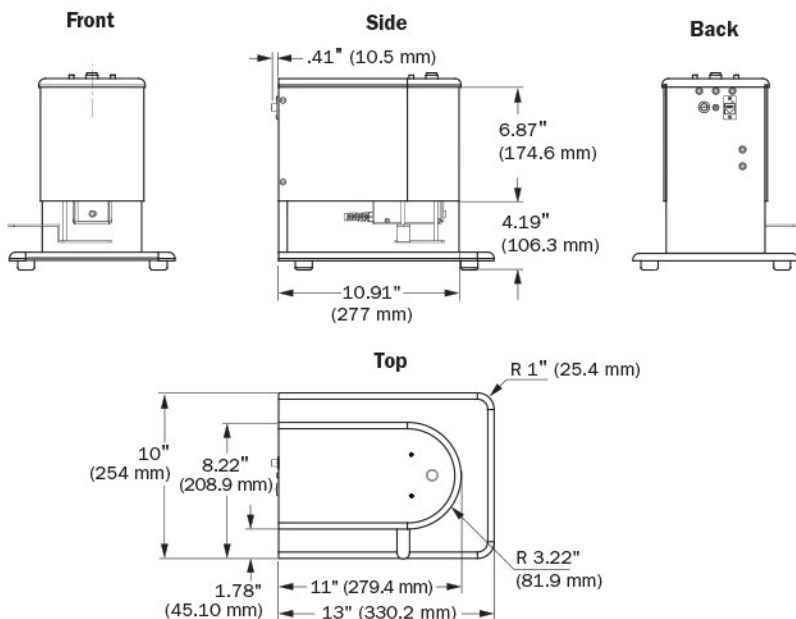

MECHANICAL

Height: 11.06" (280.92 mm)
Width: 10" (254 mm)
Length: 13" (330.2 mm)

READ PARAMETERS

Max. Label/Data Plate Thickness: 0.125" (3.175 mm)
Depth Of Field: 0.125" (3.175 mm)
Min. X dimension: 0.0075" (0.19 mm)
Image Field: 1.0" x 0.75" (25.4 mm x 19.05 mm)

ELECTRICAL

Power: AC adapter for 100 to 250 VAC, 0.05 A 50/60 Hz input; 24 V with 500 mA output

COMMUNICATION PROTOCOLS

Standard Interface: Ethernet
Maintenance Purposes: RS-232 baudrates from 600 bit/s to 115.3 Kbits/s

ENVIRONMENTAL

Operating Temperature: 0° to 40° C (32° to 104° F)
Humidity: Up to 95% (non-condensing)

LIGHT SOURCE

Type: Embedded Class I LED
External: 640 nm
 Diffuse perpendicular (90°) light
 Laser target beam
 Class II laser to IEC 60825-1

EMISSIONS/IMMUNITY

Heavy Industrial Immunity: EN 61010-1: 2002
Lead Radiation CCS: EN 60825-1 1993 Amendment 2 2001-01

MINIMUM PC REQUIREMENTS

- Host PC running Microsoft Windows 2000, Windows XP, or Windows Vista
- At least a 2 GHz CPU
- At least 512 MB RAM
- CD-ROM drive
- At least 100 MB of available hard disk space
- A 10/100 MB network (Ethernet) interface
- Display capable of displaying at least 1024 by 768 pixels, true colors

SYMBOLS VERIFIED

Data Matrix (ECC 0-200)

STANDARDS

- AIM DPM-1-2006
- ISO 16022
- ISO 15415
- ISO 15434
- ISO 15418
- SAE AS9132 Laser
- SAE AS9132 Dot Peen
- SAE AS9132 Electro-Chemical Etch
- DFAR 252.211-7003
- MIL-STD-130L
- MIL-STD-130L Change 1
- MIL-STD-130M
- MIL-STD-130M Change 1
- MIL-STD-130N
- Guide to Uniquely Marking Items Version 1.4
- Guide to Uniquely Marking Items Version 1.5
- Guide to Uniquely Marking Items Version 1.6
- ATA SPEC200 Chapter 9 and ANSI MH10

SAFETY CERTIFICATIONS

FCC, UL/cUL, CE, CB

ISO CERTIFICATION

Certified ISO 9001:2008 Quality Management System

©2015 Microscan Systems, Inc. SPO41D-EN-0111

Performance data is determined using high quality Grade A symbols per ISO/IEC 15415 and ISO/IEC 15416 in a 25°C environment. For application-specific results, testing should be performed with symbols used in the actual application. Microscan Applications Engineering is available to assist with evaluations. Results may vary depending on symbol quality. **Warranty**—One year limited warranty on parts and labor. Free extended 3 year warranty upon online product registration.



DARTRONICS, INC.

PACKAGING AUTOMATION SPECIALISTS



150 WILLIAM ST. PERTH AMBOY, NJ 08861 / TOLL FREE: 800-298-8936 / PHONE: 732-324-0800 / FAX: 732-324-4488

WWW.DARTRONICS.COM

YOUTUBE / DARTRONICS

THE SINGLE SOURCE FOR YOUR

END-OF-LINE

PACKAGING, MARKING AND CODING NEEDS